



**BUILDING CODE MANUAL  
COUNTY OF LOS ANGELES  
DEPARTMENT OF PUBLIC WORKS  
BUILDING AND SAFETY DIVISION  
Based on the 2011 LACBC**

**#89  
406.5  
Article 1  
08-09-11  
Page 1 of 3**

**PROTECTION OF SERVICE STATION FUEL DISPENSERS (PUMPS)**

Historically, fuel dispensing pumps have been protected from vehicular impact by 6 inch (152 mm) high concrete islands. The raised island has served reasonably well for the purpose of impact protection. However, the accessibility to the pump card reading element is difficult for persons with disabilities

For this reason, the California Building Code (CBC) (Division of State Architect-Access Compliance) and Part 9, Title 24 (Fire Code) of the California Code of Regulations has been amended to permit fuel pumps at grade, provided they are protected by concrete-filled steel posts, minimum of two at each end or by other equivalent means of approval by the Fire Chief

According to California Fire Code Section 2203 1 1 fuel dispensing devices at grade shall be protected at each end with a minimum of two concrete-filled steel posts, 6 inches in diameter, having a minimum 3 feet deep footing not less than 15 inches in diameter and projecting above grade at a minimum of 3 feet (914 mm) and be located not less than 4 feet nor more than 5 feet from fuel dispensers.

Fuel dispensing devices on a raised concrete island will be allowed for persons with disabilities if the fuel dispensing device manufacturers market a pump where the card readers and other reachable elements are within 54 inches of grade for a parallel wheelchair approach with no more than a 10-inch reach depth over the raised island (Refer to Chapter 11C of the CBC)

Supersedes BCM 311.2 3.2 Article 2 dated 02-03-98

WRITTEN BY JONATHAN LAM  
Civil Engineer

REVIEWED BY JUAN MADRIGAL  
Senior Civil Engineer

RECOMMENDED BY

APPROVED BY

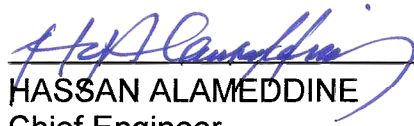

---

HASSAN ALAMEDDINE  
Chief Engineer



---

RAJ PATEL  
Superintendent of Building

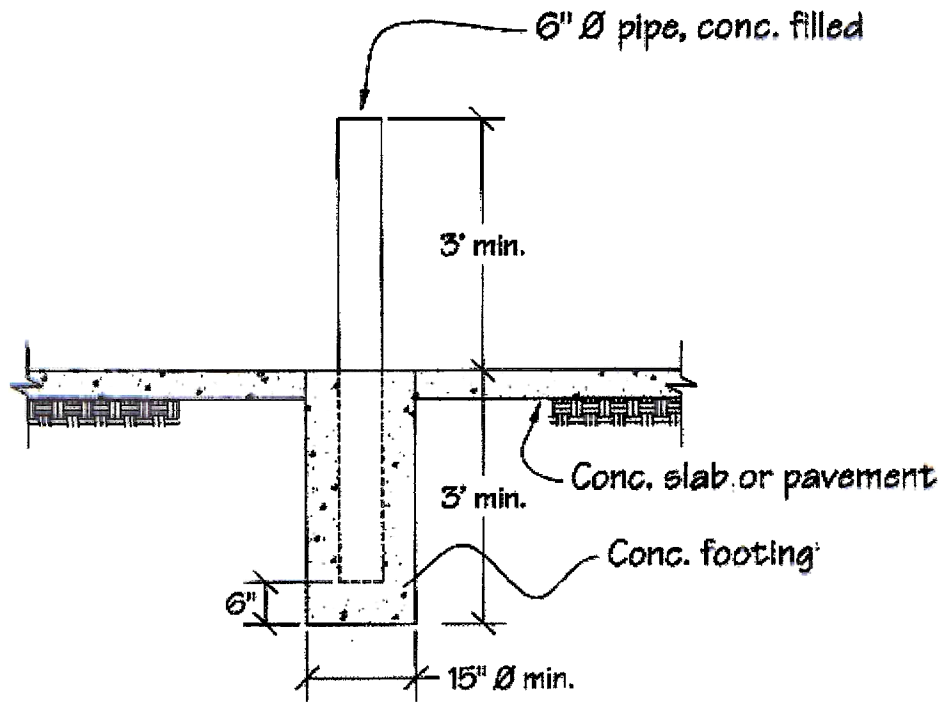
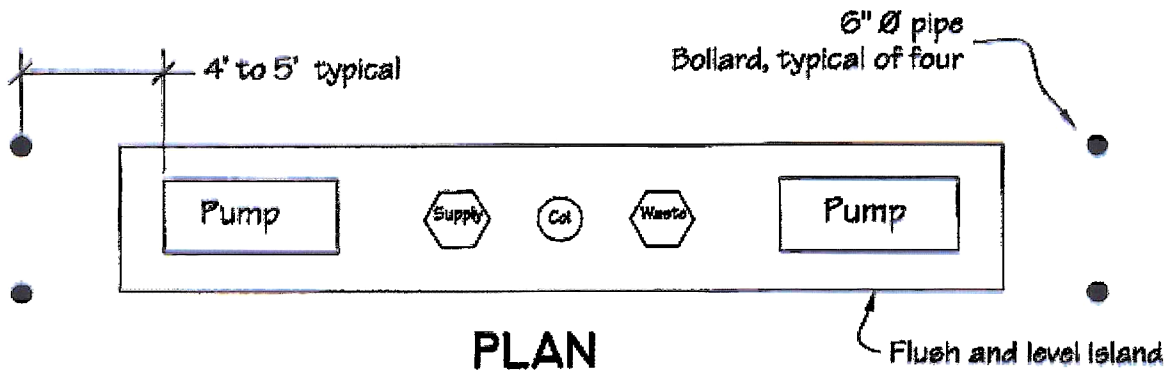

**SECTION**